

Emcom Systems

127 Route 206 South, Suite 27
Trenton, NJ 08610
www.emcomsys.com

(609) 585-5500
Fax: (609) 585-7723
info@emcomsys.com

Communications Design

H305 Door for Surface Mount Box

The H305 is a rugged, stainless steel, door assembly that may be added to an H300 surface mount box to provide further protection for telephones mounted in it. The door may be added at any time without modifications to the H300. The unit includes a lock that can be secured in the unlocked position.

Features

- **Stainless Steel Construction**
- **NEMA 4X Design**
- **Concealed SS Spring Closure**
- **Door Latches In Open Position**
- **Door Can Be Reversed**

Specifications

| | | | |
|-------------|------------------------------------|-----------|----------------------------------------------------------------|
| Material: | 16 Ga. (.062) Stainless Steel | Weight: | 7 Pounds |
| Dimensions: | 13.9" H x 11" W x 7" D (with H300) | Finishes: | Brushed Stainless, Red Powder Coat, Yellow Powder Coat (Shown) |

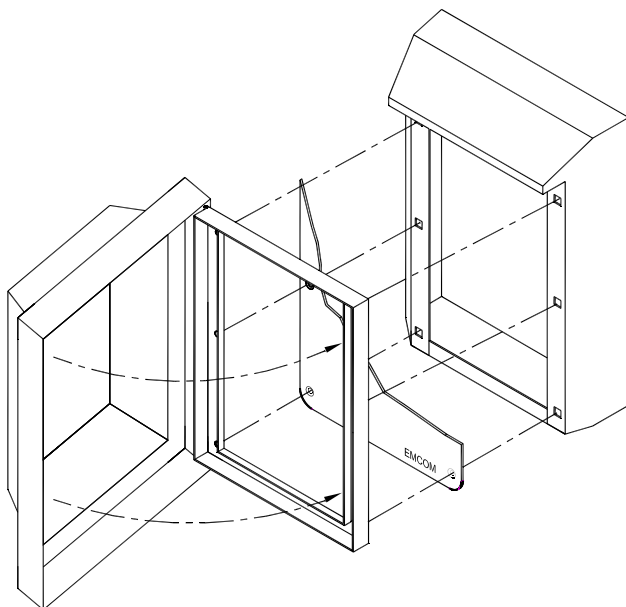

H300 Shown For Reference

REV 02/04/10

The dynamic nature of this product design dictates that the information contained in this document be subject to change without notice. Emcom Systems assumes no responsibility for errors and/or omissions contained herein.